



Drug Safes KS500

Australian Health Department Compliant

SECURITY FEATURES

- Commercial UL digital Lock and keypad
- Anti-tamper re-locking device on lock
- Hardened anti-drill plates surrounding lock
- Solid steel 12mm body
- Solid steel 12mm door
- Solid Steel bolt-work 32mm
- External hinges with internal anti-pry dead bar
- Australian health department compliant
- Durable hardened paint finished
- Adjustable shelving
- Pre-drilled 12mm anchoring holes 4 (+1 Extra) base

The Guardall range of drug safes comply with all current Australian Health Department rules, making Guardall drug safes suitable for use in all States and Territories.

(Tasmanian drug storage requirements may differ.)

PRODUCT SPECIFICATIONS

Model	EXTERNAL (MM)	INTERNAL (MM)	Weight (kg)	Volume (litres)	Shelves (adj)	SHIPPING DIMENSIONS		
	H x W x D	H x W x D				H x W x D (mm)	Weight (kg)	Type
KS500	750 x 580 x 500	700 x 530 x 390	260	145	3	900 x 600 x 600	265	Skid

DEPTH MEASUREMENT DOES NOT INCLUDE THE HANDLE, KEYPAD OR HINGES. PLEASE ALLOW 50MM.
Due to Guardall constantly striving to deliver better products; sizes and colours may vary slightly.
(H = Height | W = Width | D = Depth)

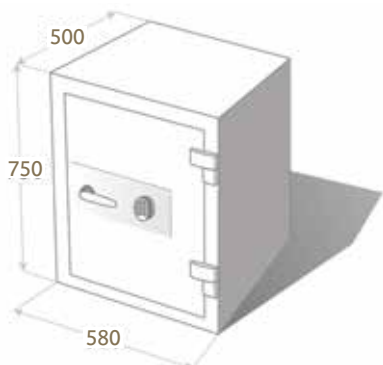

● KS500

Authorised Supplier



Safeguard Safes

safeguardsafes.com.au | 1300 764 971